



# *Milpower Source*

---

---

## **M359-1**

### **UNINTERRUPTIBLE POWER SUPPLY**

**SINGLE PHASE     2.0KW/2.5KVA**

**MADE IN THE U.S.A**

---

---

## **USER'S MANUAL**

**Milpower Source**

7 Field Lane  
Belmont, NH 03220  
Phone: (603) 267-7355  
[www.milpower.com](http://www.milpower.com)  
E-mail: [sales@mps.com](mailto:sales@mps.com)

## Table of Contents

Para	Description	Page
	Important Safety Instructions	3
1	General Description	4
1.1	Intended Application	4
1.2	Functional Overview	4
2	Electrical Installation Instructions	7
3	Front Panel Description	9
3.1	Front panel: Main Components	9
3.2	Front Panel: Indicators and Controls	10
4	Rear Panel Description	11
5	Operating the M359	12
5.1	General	12
5.2	Modes of Operation	12
5.2.1	UPS Mode	12
5.2.2	Off State	13
5.2.3	By-Pass Mode	13
5.2.4	Stand-By Mode	13
5.2.5	UPS Test Mode	13
5.3	Local Control (Using the Front panel Switches)	14
5.3.1	PWR ON/OFF Switch	14
5.3.2	INPUT UPS/BY-PSS Switch	14
5.3.3	OUTPUT UPS/BY-PSS Switch	14
5.4	Remote Control (Using the Remote Switches)	15
5.4.1	Remote PWR ON/OFF Switch	15
5.4.2	Remote UPS/BY-PASS Selector	15
5.5	Visual Indicators	15
5.6	UPS Response to Input AC Failure	17
5.7	UPS Response to Overload Condition	18
5.7.1	Output Current Limiting	18
5.7.2	Overload Protection	18
5.7.3	Recovery from Overload Shutdown	18
5.8	UPS Response to Overtemperature Condition	20
6	Maintaining the M359	21
6.1	Battery Test	21
6.2	Battery Service Life	21
6.3	Replacing the Battery Pack	22
6.4	Air Filter Maintenance	23
7	Communication and Remote Control	23
7.1	Ethernet SNMP (Optional)	23
7.2	Dry-Contacts Interface	23
7.3	RS-232 Serial Interface	25
7.4	Remote Control Interface (Remote Switches)	25
8	Specification	27
9	How to Order	30

## List of Figures

Figure	Description	Page
1	M359 Block Diagram	6
2	Electrical Connections	8
3	Front Panel, Main Components	9
4	Front Panel, Indicators and Controls	10
5	Rear Panel	11
6	Output Short Circuit Current Waveform	19
7	Output Short Circuit Shutdown	19
8	Overload (3kW) Shutdown	20
9	Dry Contacts	22
10	Remote Switches Connections	26

## IMPORTANT SAFETY INSTRUCTIONS

- The M359 and its Battery Pack should not be tampered with by unauthorized personnel. Tampering with the M359 or its Battery Pack, or using them in any other way but their intended application, may result in a severe safety hazard.
- Disconnecting the input connector does not turn off the UPS.
- The unit should only be plugged into an approved, double-pole circuit breaker electrical outlet, rated between 32Amp (min) to 46Amp (max). Note: If the available source cannot support 32Amp, consider using the Special Option Unit (see MPS Doc: M359-1-1-X\_SP).
- The M359 contains an internal high-voltage (132VDC), high-energy battery and large high voltage (270VDC) capacitors.
- The Replaceable Plug-in Battery Pack (MPS P/N M359380) of the M359 contains lead-acid batteries. The Battery Pack should not be opened. It can only be replaced with a new pack (battery cells cannot be safely replaced individually).
- Dispose the Battery Pack properly. Careless disposal (such as into a fire) may cause an explosion. Local regulations may require controlled disposal of lead-acid batteries. Please check your local regulations before disposal.
- The Battery Pack forms part of the mechanical structure of the M359. Without the Battery Pack properly installed and tightened to the M359 front panel, the ability of the M359 to tolerate mechanical vibration and shocks is compromised.
- For proper mechanical support in shipboard installation that should be able to tolerate high impact shocks:
  - ✓ Use at least three bolts on each side of the front panel.
  - ✓ Do not rely on the slides for mechanical support. Use the two pins (supplied with the M369) to support the backside of the unit.

## 1. General Description

### 1.1. Intended Applications

The M359 is a high quality, rugged, 2.0KW/2.5KVA, 19" rack-mounted, Uninterruptible Power Supply (UPS). It fully complies with all the requirements of MIL-STD-1399 (Section 300) and is specifically designed to meet the harsh military shipboard environment. The high reliability and ruggedness of the M359 make it an excellent choice not only for military shipboard applications, but for critical shore-based applications as well.

### 1.2. Functional Overview

The M359 consists of two main sections: Passive Power Conditioner and Active UPS Section (see Fig. 1). The Power Conditioner is an isolation transformer with RFI filters and spike absorbers. In case of a UPS failure, internal power relays allow the User to bypass the UPS section and feed the load directly from the output of the passive Power Conditioner. Thereby retaining the galvanic isolation, the surge protection and the noise filtering provided by the transformer and filters.

***Note: The standard 115Vac/60Hz source of a MIL-STD-1399 compliant shipboard electrical system is defined as Ungrounded Type I. In this type of source, both of the AC lines are HOT and none may be grounded. In contrast, most standard commercial equipment is designed to operate safely only from an AC source that has one side grounded (the Neutral). The Power Conditioner of the M359 (in both UPS and By-pass Modes) allows the safe usage of commercial equipment, without creating an electrical safety hazard.***

The UPS Section of the M359 is composed of a Low Input Distortion (LID) AC-to-DC Converter, Plug-in, (hot-swap) Battery Pack, Battery Charger, DC-to-AC Inverter, micro-controller-based Control Circuit and an SNMP Ethernet agent.

The LID AC-to-DC Converter is a high frequency switching converter that converts the 115Vac/60Hz input to the 270VDC output required for the DC-AC inverter. Unlike standard AC-to-DC converters (or even "high-power-factor converters"), the input current that the LID AC-to-DC converter draws from the input source is a clean sine waveform with very low harmonic distortions. This unique property enables the M359 to fully meet the stringent requirements of MIL-STD-1399 (Navy).

The Plug-in Battery Pack is a disposable unit, composed of eleven 12V/5AH lead-acid cells (sealed, lead-acid, high discharge rate, maintenance-free cells), and a temperature sensor. It provides 5 minutes of hold up time at 2KW and 10 minutes at 1.5KW. The Battery Pack is not a serviceable item cannot be disassembled, and can only be replaced as a single unit.

***Note: local regulations may require controlled disposal of lead-acid batteries. Please check your local regulations before disposal.***

The Battery Charger is a voltage-regulated and current-limited DC to DC converter. It is powered from the 270VDC output of the AC-to-DC LID Converter and provides temperature-compensated float charge to the Battery Pack. This charging method preserves the batteries and provides the longest batteries-life possible.

The DC-to-AC Inverter generates clean sine-shape 115VAC voltage from the 270VDC output of the AC-to-DC LID Converter. The DC-to-AC Inverter is current-limited and overload protected. The M359 provides failure isolation between the load on its output, to the Prime source that feeds the M359. Overloading the UPS output will not result in an overload on the prime AC source that feeds the M359.

When the UPS is in the By-pass mode, all of its active circuits (including Overload Protection) are by-passed or disabled. Therefore, overload protection in the By-pass mode should be provided by the external 32 to 46 Amp circuit breaker (or fuses) at the AC outlet that feeds the M359 input.

***Note: The Power Conditioner contains internal 60Amp fuses on its input. These internal fuses are intended only as an additional safety feature and should not be considered or used as the main overload protection devices. In the unlikely event that these fuses open, it may indicate the existence of an internal safety hazard and the M359 should be returned to the manufacturer for inspection/service. These internal fuses should never be replaced without through testing of the M359.***

The Control Circuit is a microcontroller-based circuit that provides monitoring of the unit's status (battery charge, load level, input and output levels, etc.) and supports the communication and front panel status indicators.

Figure 1, on next page, shows the main functional blocks of the M359. The relays in Figure 1 are shown in their un-energized state. For simplicity sake, only one pole is shown for each relay. However, each is a two-pole device that disconnects both of the AC lines.

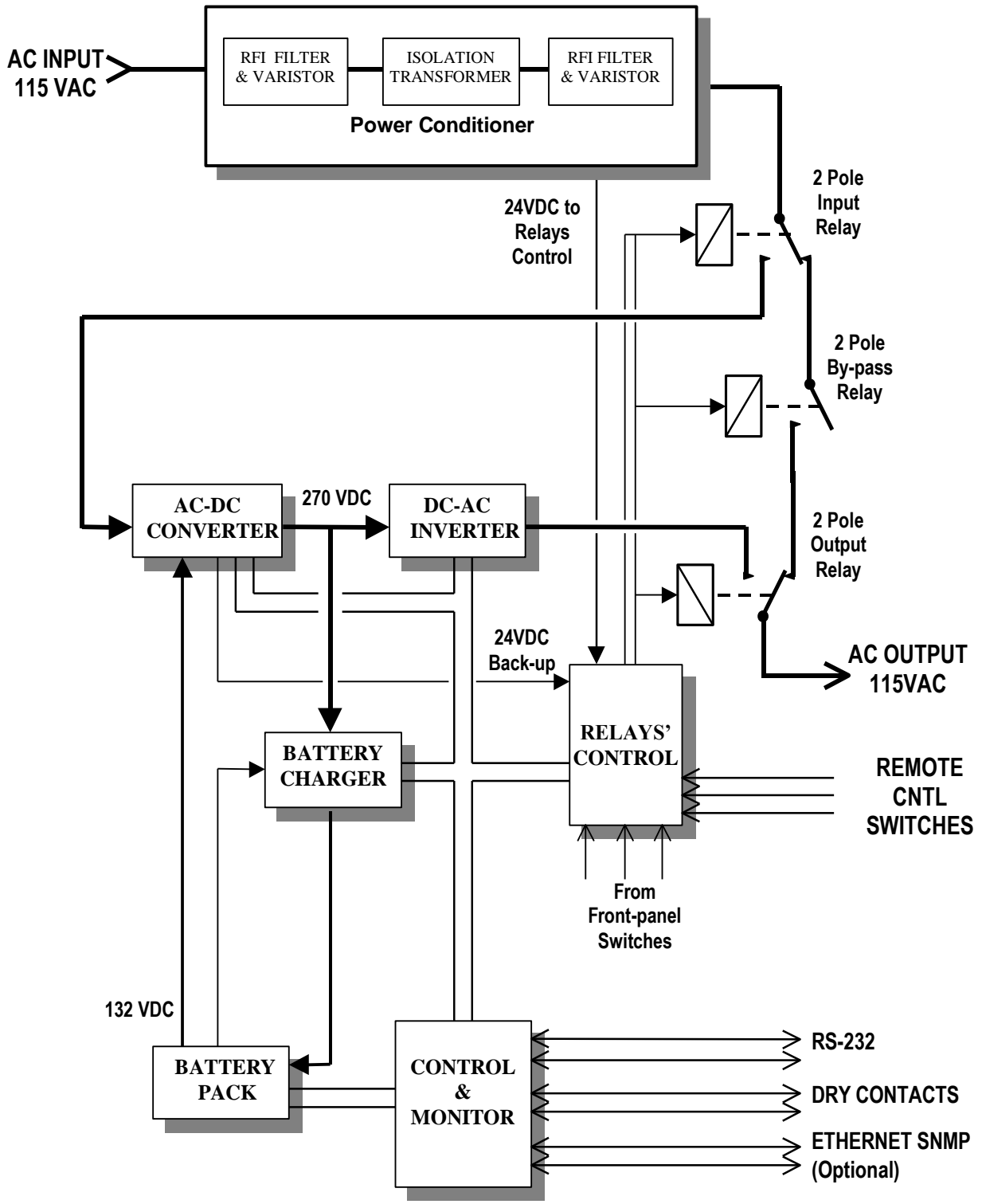

**Figure 1: M359 Block Diagram**

## **2. Electrical Installation Instructions**

- ✓ Before installing the unit, please read carefully the Safety Instructions at the beginning of this manual.
- ✓ Make sure that all the switches on the M359 front panel are in the OFF position.
- ✓ Verify that the Plug-in Battery Pack is properly installed and secured (see Paragraph 6.3).
- ✓ Verify that the electrical outlet that is powering the UPS is 115Vac/60Hz, protected by a double-pole circuit breaker (or fuses) rated to between 32 to 46Amp.
- ✓ Verify that the circuit breaker is off.
- ✓ Verify that the cables that will interface with the UPS are wired in accordance with Figure 2 (see next page).
- ✓ Ground the UPS Chassis to your rack by using at least one of the GND connections on the back-panel of the UPS. The GND conductor should be AWG #8 or thicker. (For best EMI performance use wide and short low-inductance braids).
- ✓ Connect the AC cable coming from the 115Vac-wall outlet to the Input Connector J1.
- ✓ Connect the AC cable that feeds your equipment to the Output Connector J2.
- ✓ Connect the monitoring and control cables from your server to the appropriate connectors on the UPS back panel (RS-232, Ethernet SNMP, or Dry-contacts, as applicable).
- ✓ Turn on the 115Vac circuit-breaker that provides power to the outlet that feeds the UPS.
- ✓ The UPS now is ready for operation (see Paragraph 5).

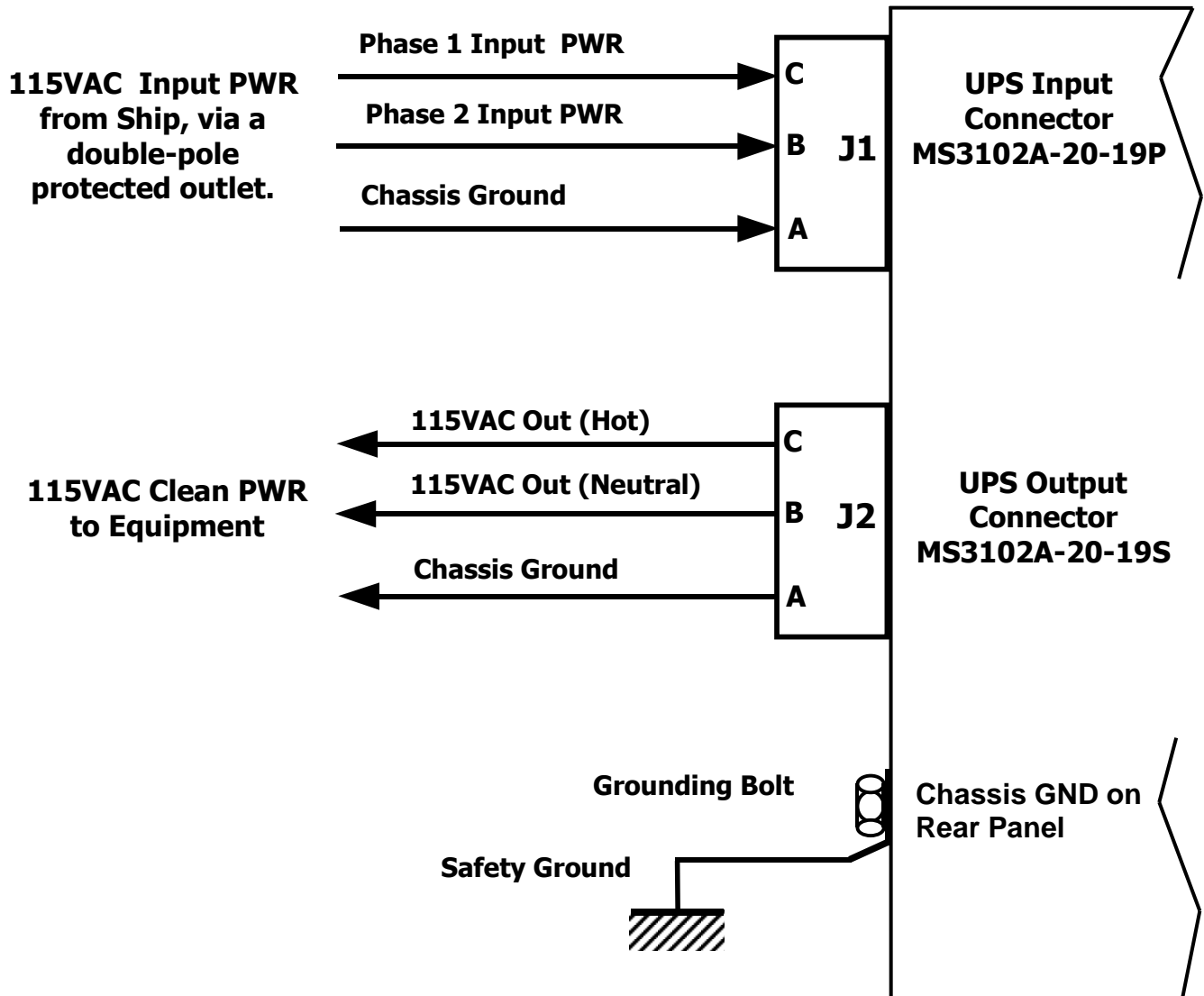

**Notes:**

- 1) Use AWG #10 (or #8) Wires.
- 2) Pin B of J2 (Output Neutral) is grounded inside the UPS by a removable jumper. Caution: removing the jumper will result in an ungrounded Neutral and may lead to a safety hazard!

**Figure 2: Electrical Connections**



### 3. Front Panel Description

#### 3.1. Front Panel: Main Components (Figure 3)

1. Visual Indicators and Controls (for detailed view see Figure 4)
2. Power On/Off Switch.
3. Air filter captive screw.
4. Removable air filter (Air Inlet).
5. Serial Number and Date Code of Battery Pack.
6. Plug-in, hot-swap Battery Pack.
7. Input UPS/By-Pass Select switch.
8. Output UPS/By-Pass Select switch.
9. Air filter captive screw.
10. Air filter captive screw.
11. Battery Pack handle.
12. Battery Pack mounting screws (total of 10, marked "A").

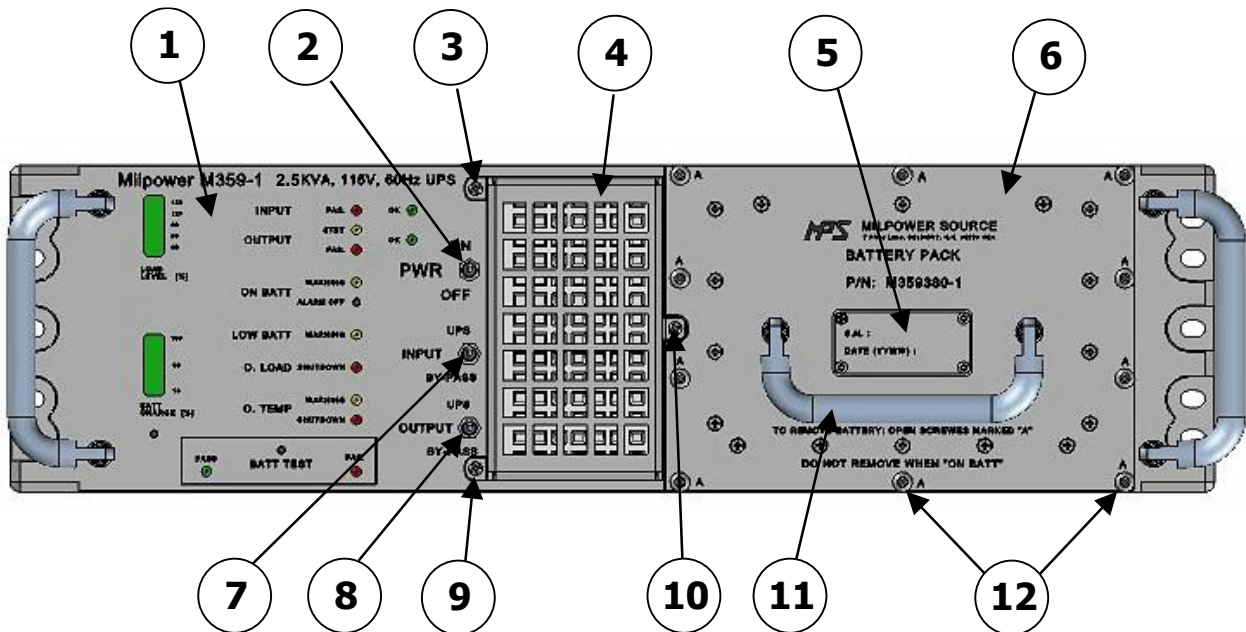

**Figure 3: Front Panel, Main Components**

### 3.2. Front Panel: Indicators and Controls (Figure 4)

13. LOAD LEVEL Bar Graph (marked in %, 100% = 2,000W).
14. LOW BATT Warning LED (blinking yellow).
15. ALARM OFF Push-button.
- Note: In M359-1 of REV-C (or higher) this button can be used to manually force the Batt Charge Level to 100%.*
16. ON BATT Warning LED (blinking yellow).
17. INPUT FAIL LED (red).
18. OUTPUT STDBY LED (yellow).
19. OUTPUT FAIL LED (red).
20. INPUT OK LED (green).
21. OUTPUT OK LED (green).
22. O. LOAD Shutdown LED (red).
23. O. TEMP Warning LED (blinking yellow).
24. O. TEMP Shutdown LED (red).
25. BATT TEST FAIL LED (red).
26. BATT TEST Push-button.
27. BATT TEST PASS LED (green).
28. Push-button, forces the Charge Indicator to 100%. Used mainly during the Manufacturer's In-process tests.  
*Note: In M359-1 of REV-C (or higher) this button was deleted and its functionality moved to the Alarm Off Push-button.*
29. BATT CHARGE Bar Graph (marked in %, 100% = Full Charge).

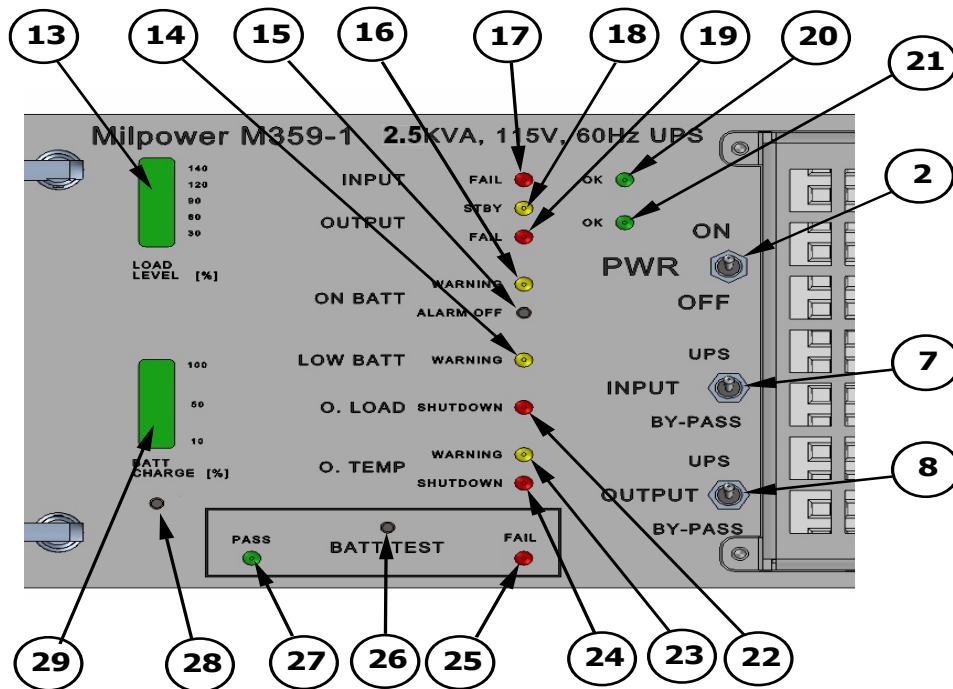

**Figure 4: Front Panel, Indicators and Controls**

#### **4. Rear Panel Description (Figure 5)**

- 30. Left side Bushing (mating pins are supplied with the unit).
- 31. Cooling fan (air outlet).
- 32. Dry Contacts Connector J3 (see Paragraph 7.2 for pin-out description).
- 33. Remote ON/OFF connector J4 (see Paragraph 7.4 for pin-out description).
- 34. RS-232 Connector J5 (see Paragraph 7.3 for pin-out description).
- 35. Right side Bushing (mating pins are supplied with the unit).
- 36. Right-side GND Connection (threaded hole, .190, UNF-32, 1.5D(min) deep)
- 37. RJ-45 (CAT-5), Ethernet SNMP Port.
- 38. Mounting Provisions (4-40 threaded holes) for Ethernet Cable Support (not provided).
- 39. J2 Output Power Connector (see Figure 2 for pin-out).
- 40. J1 Input Power Connector (see Figure 2 for pin-out).
- 41. Left-side GND Connection (threaded hole, .190, UNF-32, 1.5D(min) deep).

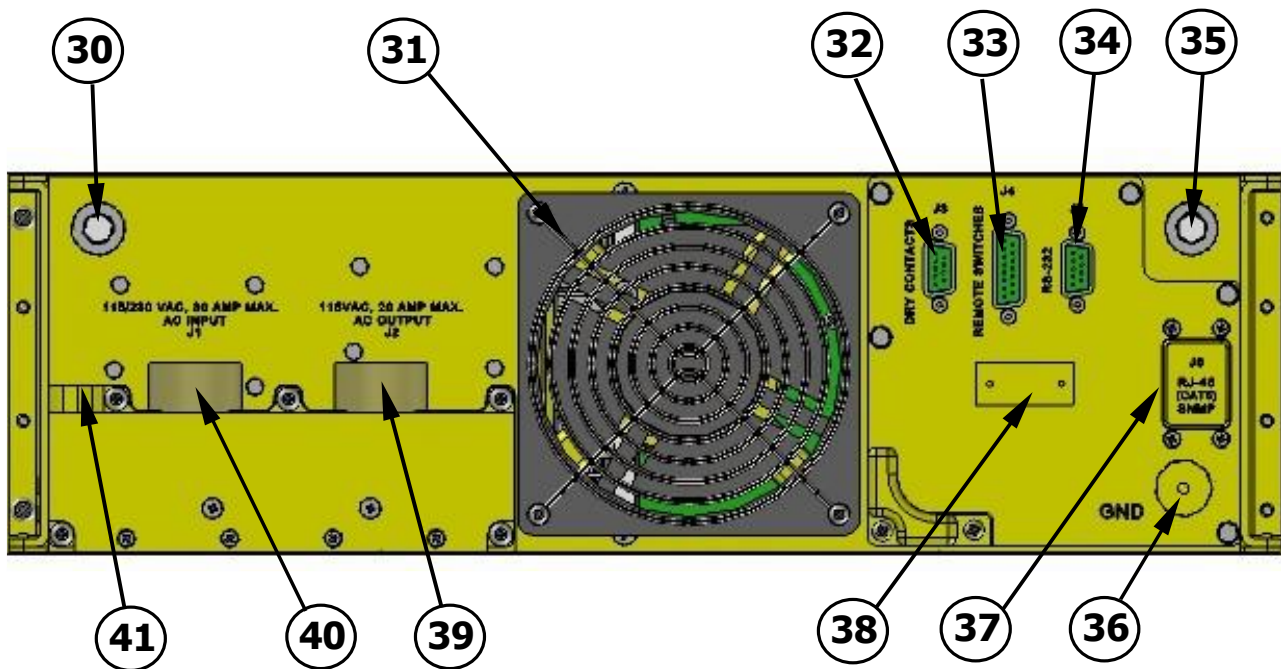

**Figure 5: Rear Panel**

## **5. Operating the M359**

### **5.1. General**

The UPS will not turn-on with Battery power alone. Therefore, to enable a UPS turn-on, AC Input must be presented at the UPS Input connector J1 and the Input UPS/By-Pass switch must be in the UPS position.

If the Remote Switches function is not used, please verify that a mating connector is plugged into J4 (on the rear panel of the Unit) and that it has two jumpers: one between Pin 8 to Pin 4 and the other between Pin 5 to Pin 6. (The UPS is shipped with the mating connector and the jumpers already installed on J4).

### **5.2. Modes of Operation.**

The M359 has five distinct modes of operation: Off, UPS Mode, By-Pass Mode, Stand-By Mode and UPS Test Mode. These modes are described below.

***Important Note! In order to avoid unintentional power surge at the equipment AC Input, always turn On the PWR ON/OFF switch only after all the other switches are in the desired position.***

#### **5.2.1. UPS Mode.**

This is the normal operating mode of the M359. In the UPS Mode all of the UPS functions are enabled and the AC Output is a clean, regulated and protected, 115Vac/60Hz power, generated by the M359 DC-to-AC Inverter. In this mode, the internal Battery supports the AC Output and failures on the AC Input will not propagate to the output.

**To enter the UPS Mode** (after all electrical connections are made and AC Input power is available):

##### **Via the front panel:**

Turn On (up) the Output UPS/By-Pass switch (8), the Input UPS/By-Pass switch (7) and only then turn On the PWR ON/OFF switch (2).

##### **Via the Remote Switches:**

Select UPS on the RMT UPS/By-Pass selector and only then turn On the RMT PWR ON/OFF switch. (See Paragraph 7.4 for description of the Remote Control Switches).

When the M359 is in the UPS mode the INPUT OK green LED (20), the OUTPUT OK green LED (21) and the Battery Charge Level Bar-graph (29) should be on. If the Battery charge level is below 35%, the LOW BATT Warning yellow LED (14) may blink. If the Battery is not fully charged, the upper bar of the BATT CHARGE indicator will blink, signifying that the Charger is active. The Load Level Bar-graph indicator (13) will show the loading on the UPS output.

### **5.2.2. Off State.**

When the M359 is OFF, the Input, the By-pass and the Output relays (see Figure 1) are not energized and are in the position shown on Figure 1. In this mode all of the UPS circuits are off and no power is presented on the AC Output connector J2. Please note that since the Input relay is located on the secondary side of the Isolation Transformer (see Figure 1), the Power Conditioner's Input is always connected to the AC input on J1.

**To turn the M359 Off via the front panel:** Turn Off (down) the PWR ON/OFF switch (2). All front panel indicators should turn-off.

**To turn the M359 Off via the Remote Switches:** Turn Off the RMT ON/OFF switch. After a short delay, all front panel indicators should turn-off.

### **5.2.3. By-Pass Mode.**

This mode is used only when the UPS has an internal failure that prevents it from providing the AC Output. In this mode the Input and Output relays (see figure 1) are in the un-energized state (as shown on Figure 1), but the By-pass relay is closed providing a direct path from the AC Input on J1, via the passive Power Conditioner to the AC Output on J2. In the By-pass Mode, none of the active circuits of the UPS are operating, hence the front panel indicators and the communication ports are all off.

**To enter the By-Pass Mode via the front panel:** Turn down the Output UPS/By-Pass switch (8) and the Input UPS/By-Pass switch (7). Turn On (if it is not all ready in the On position) the PWR On/Off switch (2).

**To enter the By-Pass Mode via the Remote Switches:** Set the RMT UPS/By-Pass selector to By-Pass position and the RMT PWR ON/Off switch to On. (The PWR ON/OFF switch (2) and the remote RMT ON/OFF switch should both be in the On position.)

### **5.2.4. Stand-By Mode.**

In this mode, all of the UPS circuits are active, except that the DC-to-AC inverter is disabled and the Output relay (see figure 1) is in the un-energized state (no AC output). This mode is used when AC Output is not desired, but other functions, like Battery charging, are. This mode can be entered only from the front panel control.

**To enter the Stand-by mode:** Turn down the Output UPS/BY-PASS switch (8) and turn On the PWR ON/OFF switch (2). The front panel display should be active and the OUTPUT STDBY yellow LED (18) will be on and the OUTPUT OK green LED (21) will be off. The LOAD LEVEL Bar-graph will also be off.

### **5.2.5. UPS Test-Mode.**

The UPS Test Mode is useful for testing the functionality of the UPS. In this mode the Input relay (see figure 1) is un-energized and the AC Output is provided by battery power. This mode can be entered only from the front panel control.

**To enter the Test Mode:** turn On the PWR ON/OFF switch (2) and after the M359 has turned on, turn down the Input UPS/BY-PASS switch (7). The AC Input is now disconnected from the UPS input and the M359 is forced to operate from the internal

battery (thus simulating an AC input failure). In this mode, the INPUT FAIL red LED (17) should be on, the ON BATT yellow LED (16) should blink, the OUTPUT OK green LED (21) should remain on, and the Bar-graphs should indicate the Load and Battery charge level.

### **5.3. Local Control (Using the Front Panel switches).**

If the M359 is controlled from its front panel switches, the remote ON/OFF switch should be in the On position and the remote UPS/BY-PASS selector in the UPS position. (If the Remote Switches function is not used, the mating connector of J4, with the jumpers described in Paragraph 5.1 above, should be installed on J4). Please note that the M359 will turn On only if AC Input is available. The M359 will remain On (using Battery power) if AC input fails, but it will not start on Battery power alone.

#### **5.3.1. PWR ON/OFF Switch (2).**

When in the Off position (down) this switch disconnects both Input and Output of the M359 and turns off all functions (regardless of anything else). When On, it enables the M359. The actual Operation Mode (UPS, By-Pass or Test) will depend on the setting of the other switches and controls. In order to turn-on the M359 both the PWR ON/OFF Switch and the INPUT Switch must be in the upper position (and AC Input must be available). **Once the M359 is On**, all Modes are accessible and depend only on the setting of the INPUT and OUTPUT switches (the exact sequence is not important).

#### **5.3.2. INPUT UPS/BY-PASS Switch (7).**

When this switch is in the By-Pass position (down), it disconnects the AC Power from the UPS input and the UPS (if already on and running) will continue to operate on Battery power. This state is useful as a **Test Mode** for the UPS functionality. If **both Input and Output** UPS/BY-PASS switches are in the By-Pass position (down) and the PWR ON/OFF switch (2) is On (up), the M359 will be in the By-Pass mode. In this mode AC power is routed (by-passed, internal to the M359) from the Input connector J1 to the Output connector J2, via the isolation transformer and passive filters and all UPS functions are disabled.

#### **5.3.3. OUTPUT UPS/BY-PASS Switch (8).**

When this switch is in the BY-PASS position (down), it disconnects the UPS AC Output from the Output connector J2. The UPS will be in the Stand-by mode, AC Output will be off, but the communication ports, the front panel display and the Battery Charger will remain active. This state is useful if the battery needs charging but the presence of AC power on the output connector J2 is undesired. If both the INPUT and OUTPUT UPS/BY-PASS switches are in the By-Pass position (down) and the PWR ON/OFF switch (2) is On (up), the M359 will be in the By-Pass mode (see 5.3.2 above).

## **5.4. Remote Control (Using the Remote Switches).**

In order to control the M359 by the remote switches (via the connector J4 on the rear panel), the three front panel switches (2, 7 and 8) should be in the upper position. The recommended connection of the remote switches is described in Para. 7.4 and Figure 10.

### **5.4.1. Remote PWR ON/OFF Switch.**

When in the Off position (down) this switch turns off the M359 (regardless of anything else). When On, it enables UPS and By-Pass operation (the actual Mode will depend on the setting of the other switches and controls).

### **5.4.2. Remote UPS/BY-PASS Selector.**

When this Selector is in the UPS position the M359 will operate as a UPS (see Paragraph 5.2.1). When in the By-Pass position, the M359 will be in the By-Pass Mode (see Paragraph 5.2.3).

If both the remote switches and the front panel switches are used, the following priority shall apply:

- 1) The M359 will be energized only if the front panel PWR ON/OFF switch (2) and the remote ON/OFF switch are both On. Turning Off either one will disconnect the input and output and will force the UPS to the Off State.
- 2) If the remote UPS/BY-PASS Selector is in the BY-PASS position, the M359 will be forced into the By-Pass Mode, regardless of the position of the front panel's Input (7) and Output (8) switches (providing that both the remote and front panel PWR ON/OFF switches are On).
- 3) If the front panel INPUT UPS/BY-PASS switch (7) and the OUTPUT UPS/BY-PASS switch (8) are both in the BY-PASS position, the M359 will be in the By-Pass Mode regardless of the position of the remote UPS/BY-PASS Selector (providing that both PWR ON/OFF switches are On).

## **5.5. Visual Indicators.**

### **5.5.1. INPUT FAIL/OK LED's (17 and 20).**

When the M359 is On and in the UPS mode, these LED's indicate the status of the AC Input into the UPS. If the AC Input is normal, the OK green LED (20) will be on. If AC Input is not provided (or too low for normal operation), the INPUT FAIL red LED (17) will be on and the INPUT OK green LED will be off. When in the By-Pass mode, all LED's are off.

### **5.5.2. OUTPUT FAIL / OK / STBY LED's (18, 19 and 21).**

When the M359 is in the UPS mode, The OUTPUT LED's indicate the status of the AC Output. When the AC Output is normal, the OUTPUT OK green LED (21) will be on. If the UPS is in the Stand-by Mode (AC output is not available in this Mode), the OUTPUT STBY yellow LED (18) will be on and the OUTPUT OK green LED (21) - off. If the AC output is not available because of an external over-load or any other failure

(external or internal to the M359) the OUTPUT FAIL red LED will be on. When in the By-Pass mode, all LED's are off.

### **5.5.3. ON BATT Warning LED (16)**

When the M359 is operating in the UPS Mode and the AC Input fails, the UPS will use the Battery power as its primary source. In this state, the ON BATT Warning yellow LED (16) will start blinking, warning the user that the UPS is working on Battery power.

### **5.5.4. LOW BATT Warning LED (14)**

When the M359 is operating in the UPS mode, and the Battery Charge level drops below 35%, the yellow LOW BATT Warning LED (14) will start blinking, warning the user that the Battery Level is low.

### **5.5.5. O. LOAD Shutdown LED (22).**

If the UPS overload protection has been tripped by an overload (and the UPS has shutdown), the red O. LOAD Shutdown LED (22) will turn on, indicating to the user that the UPS has shutdown due to overloading.

### **5.5.6. O.TEMP Warning LED (23)**

In case of an Over temperature of the UPS (hot spot temperature exceeding +94°C), the O.TEMP yellow LED (23) will start blinking.

### **5.5.7. O. TEMP SHUTDOWN LED (24).**

Three minutes after the O. TEMP Warning LED starts blinking (and if the temperature does not drop), the UPS will shut itself off. This condition is indicated by the O. TEMP SHUTDOWN red LED (24).

### **5.5.8. BATT TEST PASS LED (27).**

When Battery Test is invoked and the Battery is good, the green PASS LED (27) will be on for 20 seconds and then will turn back off.

### **5.5.9. BATT TEST FAIL LED (25).**

When Battery Test is invoked and the Battery is bad, the FAIL red LED (25) will turn (and remain) on.

### **5.5.10. LOAD LEVEL [%] Bar-Graph (13).**

A three-color bar-graph that indicates the load level (real power) in percent. 100% indicates output power of 2,000W. The lower six bars (15% to 75%) are green, the next three positions (80%, 110%, and 120%) are orange and the two uppermost positions (130% and 140%) are red. The colors do not have any special significance and are only intended to assist fast visual scanning of the load level.



### **5.5.11. BATT CHARGE [%] Bar-Graph (29).**

The Battery Charge Bar Graph indicates the charge level of the battery. 100% signifies that the battery is fully charged and will support 5 minutes at 2KW, 50% signifies 2.5 minutes at 2KW. Lower loads will result in longer hold-up time. When the Battery Charger is charging the Battery, the uppermost active segment of the Battery Charge Bar Graph will blink.

## **5.6. UPS Response to Input AC Failure**

When the input AC voltage is below the minimum level required for proper operation, the UPS will use the internal Battery to support the AC Output. During this condition the INPUT FAIL red LED (17) will be on, the ON BATT Warning yellow LED (16) will blink, and five seconds after the input power has been lost, an audible alarm will start beeping once every five seconds.

**To turn off the audible alarm**, press momentarily on the ALARM OFF Push-button (15). When the button is pressed, a short beep will sound to indicate compliance.

**Note:** *In M359-1of REV-C (or higher), this button if depressed for more than 10 seconds will set the Batt Charge Level Indicator to 100% (used during the Manufacturer's In-Process testing).*

Due to the On-line topology of the M359 (see figure 1), the output voltage is always generated by the DC-to-AC Inverter, regardless of the prime power source. Hence, the transition between AC Input to Battery Power and backward, is seamless. When monitoring the output voltage with an oscilloscope, it is impossible to tell when the transition occurs.

When the UPS operates on Battery power, the BATT CHARGE Bar Graph (29) continuously displays the remaining battery charge level. When the charge in the battery drops below 35%, the LOW BATT Warning yellow LED (14) will start blinking, indicating that the battery charge level is low and the audible alarm will start emitting two short beeps once every five seconds. To turn off the audible alarm, press momentarily on the ALARM OFF Push-button (15). When the button is pressed, a short beep will sound to indicate compliance. When the Battery Charge Bar Graph reaches 0% (no segments are lit), the UPS will continue to operate until the actual voltage of the battery will trip the Over Discharge protection circuit and will shut down the UPS. When the AC Input voltage recovers, the UPS will turn on automatically.

## **5.7. UPS Response to Overload Condition**

The M359 has two distinct overload protection functions. The first is the linear (continuous) current limiting of the output current and other is an overload protection that shuts down the UPS Output if the output power (in watts) is exceeded. In case of a shutdown due to an overload, the green OUTPUT OK LED (21) will turn off and the red OUTPUT FAIL LED (19) and the red O. LOAD SHUTDOWN LED will both be On.

### **5.7.1. Output Current Limiting**

The DC-to-AC Inverter of the UPS that generates the AC Output (see Figure 1) has a current limiting circuit that limits the output current to about 42Amp (peak). It means that the maximum undistorted sine-wave current that the M359 can provide is about 30Arms, limiting the output VA to about 3.4KVA. If the load on the UPS output exceeds this rating, the current waveform will be clamped at 42Amp peak and the output current will be a sine-wave with a “flat top”. When the overload approaches short circuit, the current wave form will look like a trapezoid (see the Figure 6).

A short circuit or an Overload that tries to exceed the current limit threshold of the UPS and as a result pulls down the output voltage to below 80Vrms and persists for more than about 0.7 second will shut down the Output of the UPS (see Figure 7).

### **5.7.2. Overload Protection**

The Overload Protection circuit of the M359 monitors the real output power into the load (in Watts). If the output power exceeds the rating of the M359 (2KW) a timer is started and if the Overload condition persists, the UPS output will shut down. The allowed overload duration before the UPS Outputs shuts down depend on the depth of the overload. For an overload of up to 150% (3KW) the allowed duration (before the output will shut down) is about 3 seconds (see Figure 8). At full short the duration will be reduced to about 0.7 seconds.

### **5.7.3. Recovery From an Overload Shutdown**

To recover from a shutdown caused by an Overload condition (the O. LOAD SHUTDOWN red LED (22) and OUTPUT FAIL red LED (21) are On):

- 1) Turn off the PWR ON/OFF switch (2), or the RMT PWR ON/OFF switch.
- 2) Remove the overload (or short circuit) from the UPS output.
- 3) Turn on the PWR ON/OFF switch (2) or the RMT PWR ON/OFF switch (as applicable, since both must be On in order to enable the UPS).

***Note: The output may turn on immediately or after a short delay, depending on the duration the unit was off. During this delay the OUTPUT STDBY yellow LED (18) will blink.***

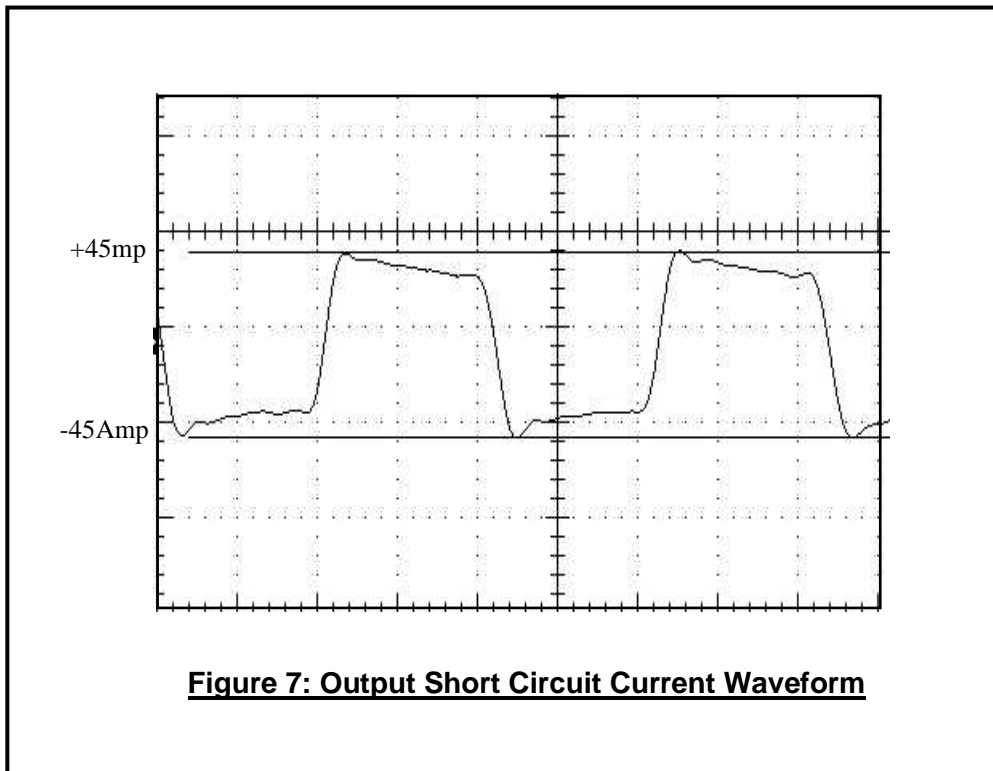
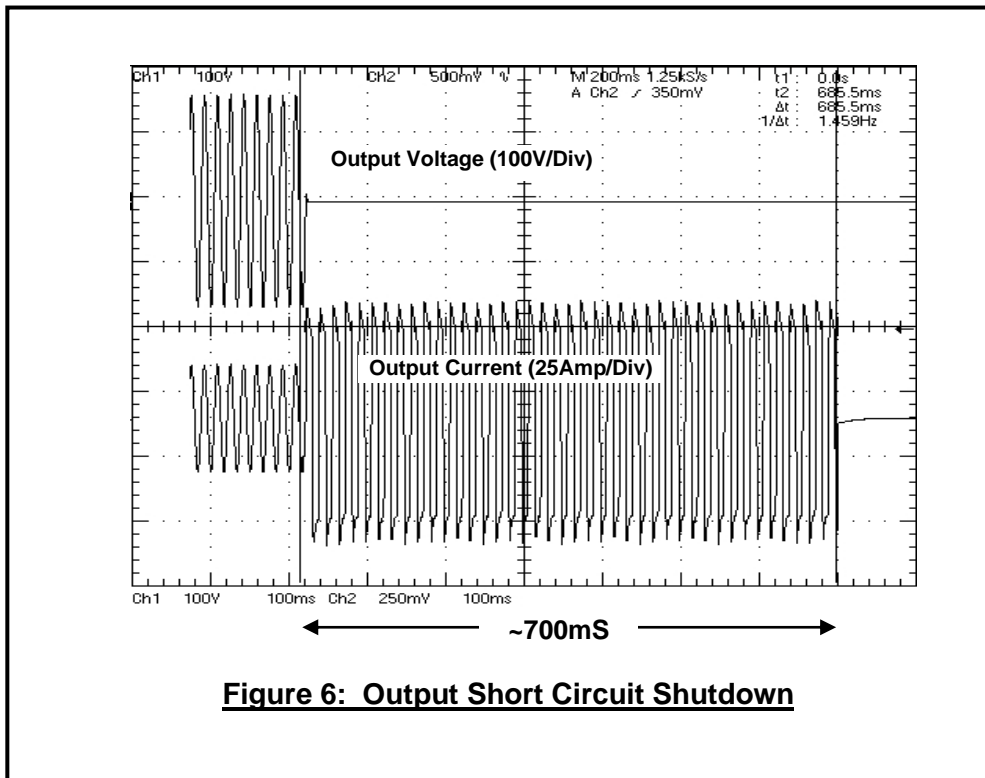

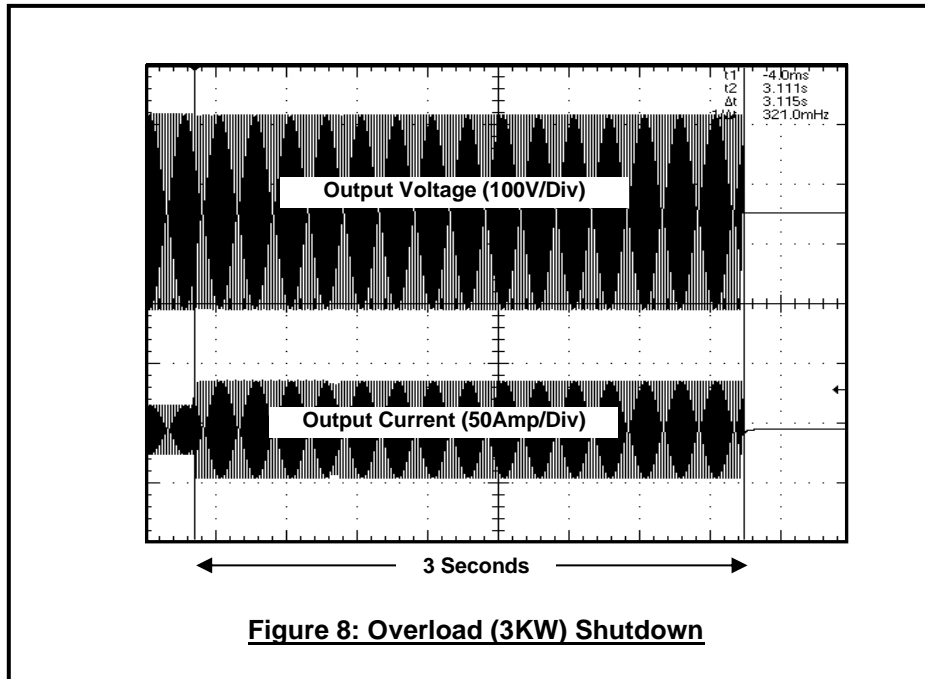

### **5.8. UPS Response to Overtemperature Condition**

When the internal hot-spot temperature of the UPS exceeds a preset level (+94°C), the yellow O. TEMP Warning LED (23) will start blinking and an audible alarm will sound at one second intervals, 50% duty cycle. Three minutes after the O. TEMP Warning LED starts blinking (and if the temperature does not drop), the UPS will shut itself off. This condition is indicated by the O. TEMP Shutdown red LED (24) and the OUTPUT FAIL red LED (19).

Recovery from Over Temperature Shutdown, when the temperature drops, is automatic. In case of an Over Temperature, check the condition of the Air Filter (4) on the front panel (if it is dirty - clean it and re-install it into the unit) and verify that when AC Output is on, the cooling fan (31) is operating..

## **6. Maintaining the M359**

### **6.1. Battery Test**

To test the Battery, press momentarily on the BATT TEST Push-button (26).

Battery Test may be invoked only when all the following conditions are true: the UPS is running on AC input power, the Battery Charge level is above 85% and the load level is above 35%. If Battery Test is denied due to low charge level ( when the BATT TEST Push-button is pressed) the BATT CHARGE Level Bar Graph will blink once.

When the Battery Test starts, the BATT TEST PASS green LED (27) will blink for about 3 seconds (indicating that Battery Test is running). After about 3 seconds, either the BATT TEST FAIL red LED (25) will turn on (and latch), indicating a bad battery, or the BATT TEST PASS green LED (27) will turn on and remain on for about 20 seconds, indicating that the Battery has successfully passed the test. The Battery Test may be repeated only after at least 20 seconds have elapsed since the last test.

### **6.2. Battery Service Life**

The gel lead-acid, sealed and maintenance-free battery used in the M359 is of the highest quality. Nevertheless, it is a Limited Life Item, and its life expectancy depends upon its operating and storage conditions.

The three most important factors that determine the life of the battery are:

- Temperature
- Storage Conditions
- Charge-Discharge Cycles

#### **6.2.1. Temperature**

The battery used in the M359 is sealed and does not “dry up” or lose gasses, but its end of service life is brought about by the gradual corrosion of the electrodes. This process is highly accelerated by high operating temperatures. Every 10°C rise above 20°C will reduce the battery service life by half.

#### **6.2.2. Battery Storage**

When lead-acid batteries are stored for extended periods of time, lead sulfate is formed on the negative plates and insulates them. The sulfating rate depends on the ambient temperature and the charge level of the battery. High temperature and low charge level accelerate the sulfating and reduce the battery life. In order to protect your battery from damage during storage:

- If practical, store in a cool place (may be stored separately from the UPS).
- Never store a discharged battery. Storing a discharged battery will damage it.
- Make sure that the battery is fully charged periodically (every 6 months at 27°C (81°F) or lower, every 3 months if higher, but not above 38°C (100°F). Charging may be accomplished by operating the UPS for six hours (can be in the Stand-by Mode).

### **6.2.3. Charge-discharge Cycles**

The number of times and the depth of battery discharges (during AC Input failure) affects the service life of the battery. If the battery is allowed to discharge only to 50% of its charge, the number of charge-discharge cycles (before it fails) will be three times the number of cycles had it been allowed to reach 30% charge. Limiting the operating time on battery power, to the minimum required by the system to perform an orderly shutdown, will prolong Battery life.

### **6.3. Replacing the Battery Pack**

The M359 uses a Plug-in, Hot-swap, Battery Pack (MPS P/N M359380) that may be ordered separately.

***Caution! The Battery Pack is an integral part of the M359 structure. Unless the M359 is in storage, it should never be left for more than a few minutes without a Battery Pack properly installed. Therefore, before removing the Battery Pack from the M359, make sure that you have a replacement Battery Pack ready and at hand.***

#### **To remove the Battery Pack (6) from the UPS:**

- 1) No need to turn off the UPS. However, before removing the Battery Pack verify that the UPS is not operating on Battery power (the ON BATT yellow LED should be off).
- 2) Open the ten size 8-32 screws marked 'A' (12) on the Battery Pack front panel.
- 3) Using the Battery Pack handle (11) pull out the Battery Pack and remove it.

#### **Caution!!**

***The Battery Pack is heavy (52 pounds), handle with care!!***

#### **To re-install the Battery Pack:**

- 1) **Carefully and slowly** plug the Battery Pack straight into its place. Never slam it in! Slamming the Battery may damage its I/O connector.
- 2) When the Battery is all the way in, use the hardware kit that came with the Battery Pack, to secure the Battery in place (insert each screw through a spring washer then a flat washer and then through the Battery Pack's panel). Tighten the screws gradually, in diagonal pattern. (Use 22±2 Lb-Inch torque).

## **6.4. Air Filter Maintenance**

The Air Filter (4) should be monitored periodically for cleanness. Dust and dirt accumulation can interfere with the cooling air-flow and may result in over temperature condition. To clean the filter:

- 1) Open the three captive screws (3, 9 and 10) holding the Air Filter.
- 2) Remove the Air Filter Assembly (as is, no need for further disassembly).
- 3) Wash the assembly with warm water and detergent.
- 4) Using dry air, remove water residue and dry the filter.
- 5) Re-install the Filter back in place and tighten the three captive screws using a torque of  $6\pm 0.6$  Lb-Inch.

## **7. Communication and Remote Control**

### **7.1. Ethernet SNMP (Optional)**

An optional Ethernet SNMP v1, v2 or v3 port is available through the J4 (37) connector on the M359 back panel. If this option is used, then the RS-232 Connector (J5) serves only as Consol and is a **DCE** (the Standard UPS RS-232 is a DTE). For details please see the UPS SNMP User's Manual.

### **7.2. Dry Contacts Interface**

Dry Contacts Interface is available through connector J3 (32), a D-Type 9P connector located on the back panel. This interface allows control and monitoring of the UPS by a server that does not have Ethernet or serial interface provision. Figure 9 below shows the dry contacts interface circuits. The pin assignment of J3 is shown on the next page.

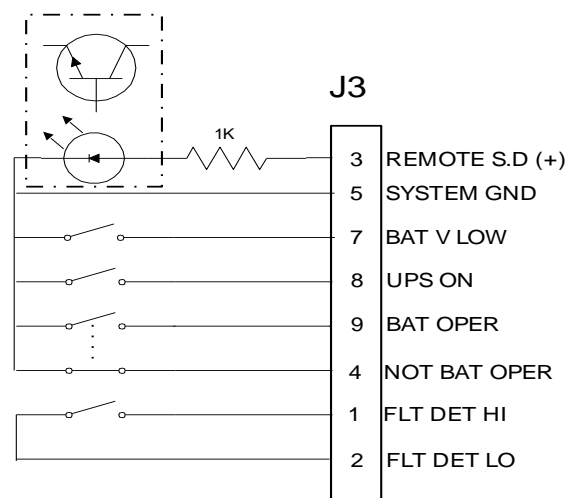

**Figure 9 - Dry Contacts**

### Connector J3 Pin Assignment

PIN	I/O	DESCRIPTION	NOTES
1	O	Fault Detect Signal Low	(1)
2	O	Fault Detect Signal High	(1)
3	I	Remote Shutdown	(2)
4	O	Not Battery Operation	(3)
5		System Common Ground	
6		N.C.	
7	O	Battery Voltage Low	(4)
8	O	UPS On	(5)
9	O	Input Power Loss, Battery operation	(3)

**Notes:**

1. Pin 1 will be shorted to pin 2 when any one of the following conditions occurs: an Over Temperature Condition, a Battery Failure, a Charger Failure, an Internal UPS Controller Failure.
2. If the UPS is running on Battery power, connecting  $8.1\pm 3.9\text{Vdc}$  between Pin 3 (+) to Pin 5 (-) will cause the UPS to shutdown (latched). If the UPS is running on AC input, applying the voltage between Pin 3 and 5 will cause the UPS to enter the Standby Mode (Ac output is off, all other functions are on.) **Note:** for Special Option Units M359-1-X-2 this pin has different function (see MPS Doc M359-1-X-2\_SP).
3. When the UPS operates on battery power, Pin 9 will be shorted to Pin 5 and pin 4 will be open. Otherwise (normal AC input), Pin 4 will be shorted to Pin 5 and Pin 9 will be open.
4. If the Battery Charge level is low, Pin 7 will be shorted to Pin 5. Otherwise, Pin 7 will be open.
5. If the UPS output is OK, Pin 8 will be shorted to Pin 5. Otherwise, Pin 8 will be open.



### **7.3. RS-232 Serial Interface**

The RS-232 serial communication interface is available through connector J5 (34), a D-Type 9S connector, located on the back panel of the UPS. This port is a DTE.

***Note: When the Optional Ethernet SNMP Agent is installed, this connector serves as RS-232 Console Interface and has different pin assignments (see the SNMP User's Manual).***

The RS-232 interface allows control and monitoring of the UPS by a host computer through the serial RS-232 communication link. For further information about this feature refer to the Software Interface Manual (available at [www.milpower.com](http://www.milpower.com)). The Table below shows the RS-232 pin assignment. On the I/O column, "Input" and "Output" entries designate input and output pins of the UPS.

**Connector J5 RS-232 Pin Assignment**

Pin	I/O	Symbol	Description
1	Internally shorted to J3 pin 5. (not used by RS232 link)		
2	Input	RXD	Receive Data
3	Output	TXD	Transmit Data
4	Output	DTR	Data Terminal Ready
5	-----	SG	Signal Ground
6	Input	DSR	Data Set Ready
7	Output	RTS	Request To Send
8	Input	CTS	Clear To Send
9	Internally shorted to J3 pin 9. (not used by RS232 link)		

### **7.4. Remote Control Interface (Remote Switch)**

***Note: The M359 is shipped with a mating connector plugged into J4, with jumpers that enable the unit. If remote control is not desired, do not remove this connector.***

The Remote Control Interface J4 (Fig 10, on next page) provides a means for turning the UPS ON and OFF and selecting between the UPS Mode and the By-Pass Mode from a remote panel's switches. The Pin assignment of J4 is shown on the next page.

Pins 3, 4 and 5 are connected in parallel and serve as a Common Signals Return.

When Pin 8 (the remote PWR ON/OFF pin) is connected to the Common Signals Return, the M359 is enabled. Opening Pin 8 will disable the M359 (opening all internal relays and removing power from the Output) regardless of any other control or switch.

When Pin 6 (the remote UPS Select Pin) is connected to the Common Signals Return (and Pin 7 is open, the UPS Mode will be enabled.

When Pin 7 (the remote By-Pass Select Pin) is connected to the Common Signals Return and Pin 6 is open, the UPS will be forced into the By-Pass Mode (providing that Pin 8 is also connected to the Common and the front panel PWR ON/OFF switch is in the On Position.)

The remote switches should be rated to 28Vac, 0.25AMP.

**Note:** To control the UPS by the remote switches, leave all the front panel switches in the upper position.

Turn the UPS On/Off by connecting/disconnecting Pin 8 to the Common.

Select the operation mode (UPS or By-Pass) by toggling the Common between Pin 6 and 7. (See Figure 9 below).

J4: D-Type-15S	
Pin	Symbol
3, 4 and 5	Common Signals Return
8	Remote PWR ON/OFF
6	Remote UPS Select
7	Remote By-Pass Select

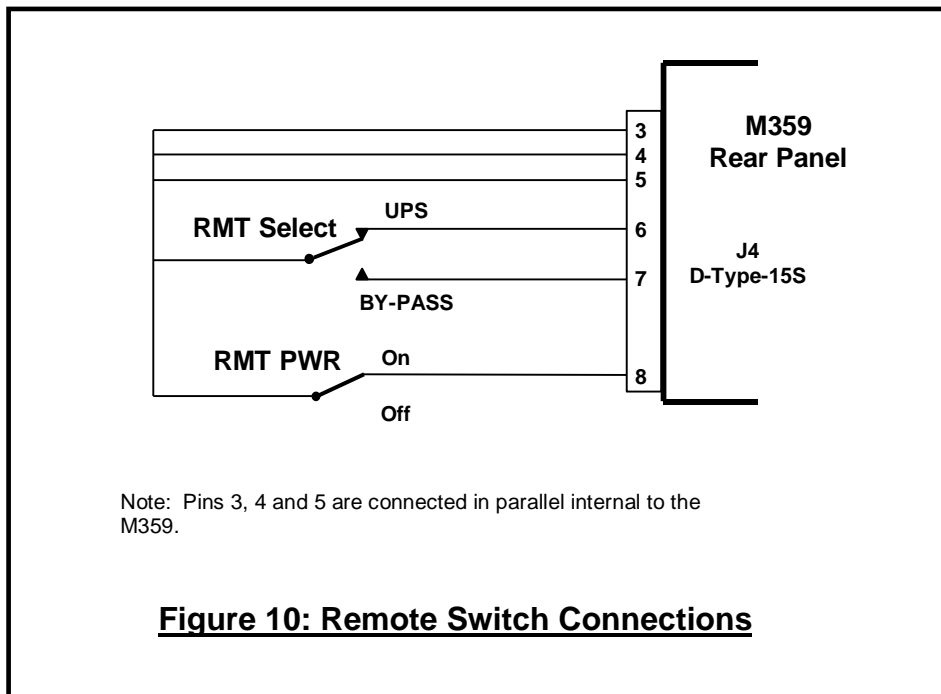

## 8. Specification

<b>INPUT</b>	<b><i>Voltage Range</i></b>	0 - 155VAC In Accordance with MIL-STD-1399 (Navy)
	<b><i>Switchover Voltage</i></b>	<102VAC, below this voltage the M359 may switch to Battery power. (Note: MIL-STD-1399 worst-case min. steady state voltage is 107VAC.)
	<b><i>Frequency</i></b>	48-64 Hz
	<b><i>Power Factor</i></b>	> 98%
	<b><i>Spikes</i></b>	200 joules clamping device I.A.W. MIL-STD-1399 (Navy)
	<b><i>Isolation</i></b>	Input is galvanically isolated from output and chassis (> 1 M $\Omega$ at 600VDC). Total capacitance between input and chassis is less than 0.02uf per line. Leakage current is less than 2ma. (130dB Input Isolation Transformer.) Both input wires may be "hot" I.A.W. MIL-STD-1399.
	<b><i>Current waveform</i></b>	Sinusoidal with harmonic content of less than 2.5% for harmonics between 2fo to 32fo and less than 100%/N for harmonics between N=32 and 20kHz. (I.A.W. MIL-STD-1399)
	<b><i>Line impedance</i></b>	Up to 5 ohms between 100 to 200kHz (I.A.W. MIL-STD-1399)
<b>OUTPUT</b>	<b><i>Voltage</i></b>	115Vac $\pm$ 3%, grounded Neutral (Note 1).
	<b><i>Power Rating</i></b>	2.0KW (2.5KVA) Continues, up to ambient temperature of +40°C. Derate linearly to 1.5KW at +52°C (ambient), (Note 2).
	<b><i>Frequency</i></b>	60Hz $\pm$ 0.2% (digitally synthesized from a crystal oscillator)
	<b><i>Waveform</i></b>	Sinusoidal , THD of 2% (linear load), 6% (non-linear)
<b>BATTERY</b>	<b><i>Type</i></b>	Front Panel Loaded, Hot-swap Plug-in, encapsulated, sealed, maintenance-free, lead-acid, Battery Pack.
	<b><i>Capacity</i></b>	2KW for at least 5 minutes. 1.5KW for at least 10 minutes.
	<b><i>Charger</i></b>	Low ripple, regulated voltage, float-charger, with current limiting and temperature compensation. Fully charges the battery within 6 hours (following 5-min. discharge at 2.0 kW).
	<b><i>Protection</i></b>	Battery is protected from over-discharge and thermal runaway by internal protection circuit.
	<b><i>Monitor</i></b>	The Battery charge level and internal impedance are monitored by the UPS micro-controller.
<b>EMC</b>	<b><i>RFI</i></b>	MIL-STD-461F Requirements: RE101, RE102, CE101, CE102, CS101, CS116 (AC Input) and RS103.
	<b><i>ESD</i></b>	All I/O lines are protected from ESD.

<b>ENVIRONMENT</b>	<p><b>Temperature</b></p> <p><b>Humidity</b></p> <p><b>Altitude</b></p> <p><b>Orientation</b></p> <p><b>Mechanical Shock</b></p> <p><b>Vibration</b></p>	<p>Non-operating: -40 to +72°C (Note 3) Operating: 0 to + 52°C (Note 2)</p> <p>Up to 95%, non-condensing.</p> <p>Operating: Up to 10,000 feet. Non-operating: (Air transport) 40,000 feet.</p> <p>May be installed at any orientation.</p> <p>When packed, withstands the free fall drop and edgewise drop IAW Methods 5007.1 and 5008.1 of Federal Test Method standard 101C. When operating, withstands the high-impact shipboard shock IAW MIL-S-901D, Grade A, Class I and II.</p> <p>Type I vibration IAW MIL-STD-167-1. Random vibration IAW MIL-STD-810D, Cat. 9, Proc. I (test condition I-3.2.11, Fig. 514.3-34)</p>
<b>INDICATIONS &amp; CONTROL</b>	<p><b>Visual Indications (Front panel)</b></p> <p><b>Test Mode</b></p> <p><b>Audible Alarm</b></p> <p><b>Power Switches</b></p> <p><b>Remote Control</b></p>	<p>10-segment tri-color Bar Graph for load level display. 10-segment Bar Graph for battery charge level display. "Output OK", "Output Fail" and "Standby" status lamps. "Input OK" and "Input Fail" status lamps. "On Batt " status lamp. "Batt Passed" and "Batt Failed" lamps for battery self-test. "Low Batt" warning lamp. "Overload Shutdown" status lamp. "Overtemp warning" and "Overtemp Shutdown" lamps.</p> <p>When test mode is invoked by pressing the push-button on the front panel, the UPS performs battery impedance testing without interrupting the output power (even if the battery fails) utilizing a proprietary time-sharing circuit. The test results are displayed on the panel indicators. End-to-End testing of the UPS is accomplished by cycling the INPUT UPS/BY-PASS switch on the front panel.</p> <p>The UPS will beep when it operates on battery power or during over-temperature condition. The alarm may be silenced by pressing the "Alarm Off" push-button on the front panel.</p> <p>The M359 has three double-pole power relays, one on the input, one on the output and a third relay that bypasses the UPS section. The front panel switches allow the user to control these three power relays.</p> <p>Connector J4 on the back panel, allows the controlling of the M359 by a remote 28Vdc/0.25A single pole, On/Off switch (Remote Power On/Off ) and a 28Vdc/0.25A, ON-ON, single pole switch (Remote UPS/By-Pass Select).</p>

<b>INTERFACE</b>	<i>Discrete interface</i>	<p>Four dry contacts indicating the following conditions:          "UPS ON" (Output OK)          "Battery Voltage Low"          "Input Power Loss" (Battery Operation)          "Fault Detect"</p> <p>A "Shutdown" input (via opto-isolator) for remote shutdown of the UPS during AC input fail. When the AC input recovers the UPS will automatically turn ON.</p>
	<i>Serial Interface</i>	<p>RS-232 Serial port (EIA-RS-232).          The serial port allows transmission of status and reception of User-Programmable Options, some of which are described below:  <b>Status:</b> Input OK, Output OK, On Battery, Low Battery, Over-Temperature Warning, Battery Test Passed/Failed, Load Level, Charge Level, status of all User Programmable Options and failure diagnostic.  <b>Commands:</b> UPS Shutdown, UPS Standby, Initiate Battery Test, Enable/Disable Periodic Battery Test, Enable/Disable Battle Mode, Enable/Disable Aural Alarm, Set Input power Limit (see Note 2), Protection Reset (resets all latching protection circuits), System Reset (forces all User Programmable Options into their default state and resets all latching protection circuits).</p> <p>For the complete set of the available Status messages and Commands, refer to the "UPS_Soft_1" Software Interface Manual. (Available at <a href="http://www.milpower.com">http://www.milpower.com</a>).</p>
	<i>Ethernet SNMP Port</i>	<p>Optional, RJ-45, CAT-5 SNMP v1, v2 or v3 Port with Server/ Client Monitor Software. Allows monitoring of the UPS (using MIBs). Supports user defined event-triggered shutdown. Supports different shutdown timing for each Client in the net. Supports delay UPS shutdown (after the Server has been shut down).</p>
<b>SCREENING</b>		Each unit is subjected to a Power Burn-in of 24 hours. Additional ESS is available upon request.
<b>ACOUSTIC NOISE</b>		Less than 48dBA.
<b>FUNGUS</b>		Does not support fungus growth, in accordance with the guidelines of MIL-STD-454, Requirement 4.
<b>WEIGHT and SIZE</b>		140 Pounds. (88 Pounds without the Battery Pack. Add 8 pounds for M359-1-2 ) 19", 3-U, 22" deep, Rack mount or Hard mount.

**Notes**

1. The Neutral Grounding Link is accessible to the user and may be removed to obtain a floating output (not recommended, may result in a safety hazard).
2. The long-term maximum loading of the UPS Output is limited by the fan's cooling capacity. At ambient temperature above 40°C, the maximum steady-state output power should be derated to 1.5KW at 52°C. For short term loading (less than 5 minutes) no derating is required.
3. High temperature for prolonged duration will shorten the battery life.

## 9. How to Order

Order P/N: **M359-1 -0 -0 -0 -0**

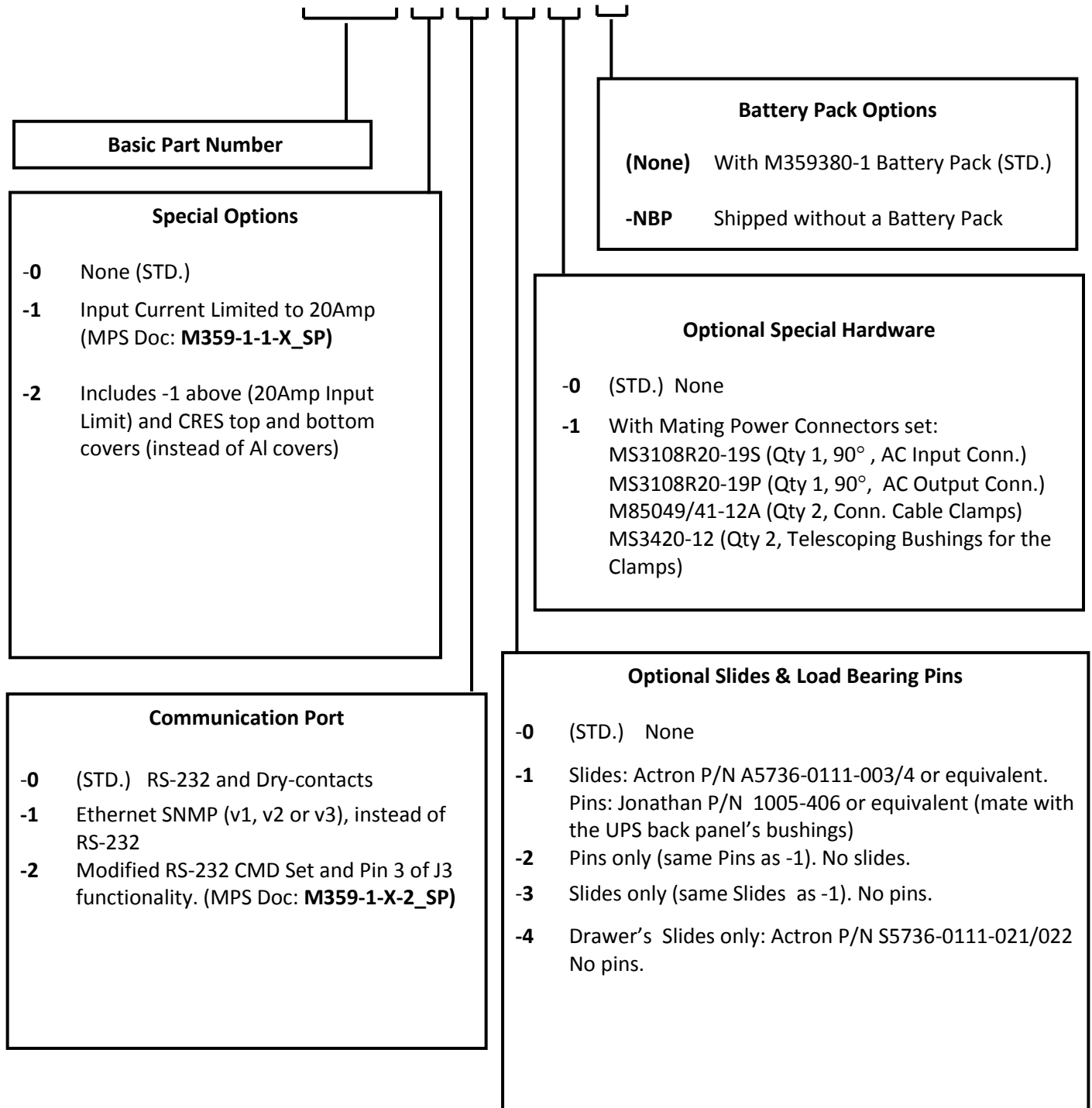

### Basic Part Number

### Special Options

- 0 None (STD.)
- 1 Input Current Limited to 20Amp (MPS Doc: **M359-1-1-X\_SP**)
- 2 Includes -1 above (20Amp Input Limit) and CRES top and bottom covers (instead of AI covers)

### Communication Port

- 0 (STD.) RS-232 and Dry-contacts
- 1 Ethernet SNMP (v1, v2 or v3), instead of RS-232
- 2 Modified RS-232 CMD Set and Pin 3 of J3 functionality. (MPS Doc: **M359-1-X-2\_SP**)

### Battery Pack Options

- (None) With M359380-1 Battery Pack (STD.)
- NBP Shipped without a Battery Pack

### Optional Special Hardware

- 0 (STD.) None
- 1 With Mating Power Connectors set:  
MS3108R20-19S (Qty 1, 90°, AC Input Conn.)  
MS3108R20-19P (Qty 1, 90°, AC Output Conn.)  
M85049/41-12A (Qty 2, Conn. Cable Clamps)  
MS3420-12 (Qty 2, Telescoping Bushings for the Clamps)

### Optional Slides & Load Bearing Pins

- 0 (STD.) None
- 1 Slides: Actron P/N A5736-0111-003/4 or equivalent.  
Pins: Jonathan P/N 1005-406 or equivalent (mate with the UPS back panel's bushings)
- 2 Pins only (same Pins as -1). No slides.
- 3 Slides only (same Slides as -1). No pins.
- 4 Drawer's Slides only: Actron P/N S5736-0111-021/022  
No pins.